



## Application Note #TBD

# Driving Relays With FGRIO-M Digital Outputs

### October 16,2009

#### Background

The FGRIO Master (FGRIO-M) radio is used in signal replication applications to wirelessly reproduce digital and analog inputs from a remote location. Signal replication is also referred to as wire-replacement. In some installations, users have a need to drive relay control switches. However, the drive strength of the FGRIO-M digital outputs is too low to drive the coil of a relay. The digital outputs can only drive up to 4mA and some relays require up to 200mA. This application note describes how to drive a relay with the FGRIO-M digital outputs.

#### Important Note:

Never connect a voltage source to a radio greater than the radio's supply voltage. Doing so may cause irreversible damage to the radio and external equipment.

#### Results:

The drive strength of the FGRIO-M digital outputs is limited by internal circuitry. Specifically, a 330 ohm resistor is placed in series with the digital output. To overcome the series resistor, add a NPN bipolar junction transistor (BJT) to the FGRIO-M digital output. Using the transistor's high current gain will allow the relay to be driven at its full current and voltage rating. Adding the transistor will also invert the logic signal from the FGRIO-M digital output. Ensure that the relay's output connections are modified accordingly.

Add the transistor to the FGRIO-M digital output according to the wiring diagram in figure 1 by following these steps:

1. Connect the base of the NPN BJT to the digital output.
2. Connect the collector of the NPN BJT to the relay.
3. Connect the emitter of the NPN BJT to signal ground.

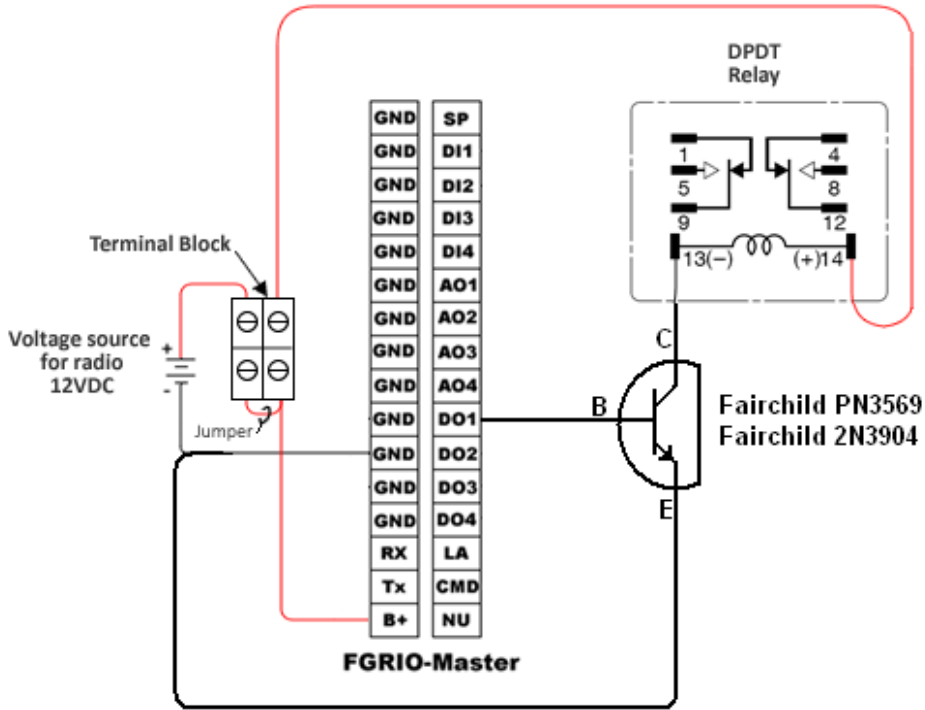

Figure 1. Wiring diagram to drive relays with FGRIO-M digital outputs.

**Component Selection**

For relays requiring drive strength below 200mA use part 2N3904 from Fairchild Semiconductor. The cost per 2N3904 transistor is \$0.11 from Digikey ([www.digikey.com](http://www.digikey.com)) or \$0.79 from Radio Shack ([www.radioshack.com](http://www.radioshack.com) or call your local Radio Shack store for in-store availability). For relays requiring drive strength below 300mA use part PN3569 from Fairchild Semiconductor. The cost per PN3569 transistor is \$0.21 from Digikey ([www.digikey.com](http://www.digikey.com)). Selection criteria for both transistors were low cost and high availability.

In the unlikely event that higher current drive is required, select the NPN BJT accordingly. Calculate the transistor needs based on driving the transistor in saturation with less than 4mA.